

# PAS 24:2022 - Enhanced Security Performance Requirements for Doorsets and Windows in the UK

**UAB Panorama Nordic**

**Test Report No. R4791640618-4**

16 September 2025

# Table of contents

- Table of contents ..... 2
- 1. Introduction ..... 3
- 2. Summary of Results ..... 5
- 3. Description of Test Sample ..... 6
- 4. Test Arrangement ..... 11
- 5. Test Procedures ..... 14
- 6. Test Results ..... 17
- 7. System Drawings ..... 22

# 1. Introduction

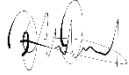
Test Details	
Customer:	UAB Panorama Nordic Vingio G. 5 Vingio G. 5 Naujiejai Muniskiai, 54317 LT
Product tested:	SD66 Sliding door
Date(s) sample(s) received:	13 <sup>th</sup> August 2025
Date of test:	26 <sup>th</sup> August 2025 & 8 <sup>th</sup> September 2025
Test conducted at:	UL International (UK) Limited Halesfield 2 Telford Shropshire TF7 4QH
Test conducted by:	D Adams <i>Senior Engineering Technician</i> S Ward <i>Engineering Technician</i> C Holden <i>Laboratory Engineer</i> D Whittall <i>Laboratory Assistant</i>
Report Authorisation	
Report compiled by:	C Holden Laboratory Engineer 
Authorised by:	E Round Laboratory Engineer 

UL International (UK) Limited, Unit 1-4 Horizon, Kingsland Business Park, Wade Road, Basingstoke, Hampshire RG24 8AH, is accredited by the United Kingdom Accreditation Service as UKAS Testing Laboratory No. 5772.

**REPRODUCTION OF THIS DOCUMENT IN WHOLE OR ANY PART THEREOF MUST NOT BE MADE WITHOUT PRIOR WRITTEN PERMISSION FROM UL INTERNATIONAL (UK) LIMITED.**

This report and the results shown within are based upon the information, drawings, samples and tests referred to in the report. The results obtained only apply to the sample tested and do not necessarily relate to samples from the production line of the above-named company and in no way constitute any form of representation or warranty as to the performance or quality of any products supplied or to be supplied by them. UL International (UK) Limited or its employees accept no liability for any damages, charges, cost or expenses in respect of or in relation to any damage to any property or other loss whatsoever arising either directly or indirectly from the use of the report.

UL International (UK) Telford Laboratory is authorised to act as a UK Approved/Notified Laboratory n. 0843 under the UKCA system and Northern Ireland provisions for the activities covered by this Report according to BS EN 14351-1:2006+A2:2016. The Approved/Notified Body number shall be used only when and, in the manner, authorized by the Approved/Notified Body. The Customer agrees that the Approved/Notified Body shall retain the right to control the use of the Report and Approved/Notified Laboratory number. If copies of Report documentation are provided to others it shall be reproduced in their entirety. Customer agrees that the promotion of its product utilizing the name, Report, or Approved/Notified Laboratory number of UL would mislead the public if such product is not covered by a Report issued by the Notified Laboratory; does not comply with the Applicable Requirements and applicable laws, regulations, and standards; or is used in any way not authorised by UL.

## 2. Summary of Results

The following table summarises the results of tests, conducted in accordance with PAS 24:2022, achieved by the test specimen(s) supplied:

<b>Test description</b>	<b>Sample (ID No.)</b>	<b>Test sheet reference</b>	<b>Result</b>	<b>Test date</b>
A.3.1 – Security hardware & cylinder test – Part 1	4	TS002	<b>Pass</b>	8 <sup>th</sup> September 2025
A.3.2 – Security hardware & cylinder test – Part 2	3	TS002	<b>Pass</b>	8 <sup>th</sup> September 2025
A.3.3 – Security hardware & cylinder test – Part 3	2	TS001	<b>Pass</b>	26 <sup>th</sup> August 2025
B.4.6 – Manual check test	1	TS001	<b>No entry gained</b>	26 <sup>th</sup> August 2025
B.4.4.3 – Infill – mechanical test	2	TS001	<b>Pass</b>	26 <sup>th</sup> August 2025
B.4.3 – Manipulation test (a)	2	TS001	<b>Pass</b>	26 <sup>th</sup> August 2025
B.4.4.4 – Manual cutting test	2	TS001	<b>Pass</b>	26 <sup>th</sup> August 2025
B.4.5 – Mechanical loading test	3	TS002	<b>Pass</b>	8 <sup>th</sup> September 2025
B.4.4.2 – Infill – manual test	1	TS001	<b>Pass</b>	26 <sup>th</sup> August 2025
B.4.8 – Soft body impact test	1	TS001	<b>Pass</b>	26 <sup>th</sup> August 2025
B.4.9 – Hard body impact test	1	TS001	<b>Pass</b>	26 <sup>th</sup> August 2025
<b>Overall classification in accordance with PAS 24:2022</b>			<b>D</b>	

More comprehensive details are reported in section 6.

**Note:** *These results are valid only for the conditions under which the test was conducted.*

*All measurement devices, instruments and other relevant equipment were calibrated and traceable to National Standards.*

### 2.1 Decision rule

Classifications reported in section 6 indicate that the product conforms with the relevant accuracy requirements of section B.3 and C.3 of PAS 24:2022.

### 2.2 Uncertainty of measurement

The results as reported in this test report are not accounting measurement of uncertainty as no numerical values were recorded during the test.

### 3. Description of Test Sample

The details shown in section 3 and drawings shown in section 7 have been supplied by and confirmed as typical of normal production by UAB Panorama and have not been verified by UL International (UK) Limited.

See Section 7 for sample drawings as supplied by the Customer

<b>General Information</b>	
<b>Project number:</b>	4791640618
<b>Product range name:</b>	Sliding doors 66
<b>Project name to appear on front page of the test report:</b>	UAB Panorama Nordic Vingio G. 5 Vingio G. 5 Naujiejai Muniskiai, 54317 LT
<b>Configuration:</b>	2 leaf sliding doors TD2
<b>Opening direction:</b>	Sliding from right to left
<b>Product manufacturer:</b>	Panorama Nordic
<b>The sample is typical of normal production:</b>	yes
<b>Please define the closing condition of the sample: I.e. Closed, fastened, latched, locked and secured etc.</b>	Locked and secured
<b>Weight of Sample including subframe (kg):</b>	About 260kg
<b>Weight of sash (kg) - applicable for sample tested with accordance with BS 6375-2:2009</b>	About 90kg with glass unit

<b>Outer Frame</b>			
Height:	2490	<b>Outer frame gasket</b>	
Width:	2490	Gasket type:	Silicon
Outer frame material:	pine	Manufacturer:	Sipla AB
Surface finish	Not painted	Product name:	Gasket 10mm
<b>Outer frame Part Numbers</b>		Product code:	SS10
Top:	12	<b>Threshold</b>	
Bottom:	25	Manufacturer:	HYDRO / Panormana Nordic
Lock side:	14	Product name:	Treshold 25mm
Hinge side:	13	Product code:	25
<b>Outer frame section size</b>		Material:	Aluminium + sapele wood
Width:	40	<b>Outer frame joint method</b>	
Depth:	133	Head:	
<b>Reinforcing:</b>		Foot:	
Manufacturer:			
Product name:			
Product code:			
Material:			

<b>Leaf, Sash, or Casement - 1</b>			
Width:	1249	<b>Leaf / casement gasket</b>	
Height:	2405	Gasket type:	Silicon
Material:	Pine	Manufacturer:	Sipla AB
Surface finish:	Not painted	Product name:	Gasket 10mm
<b>Leaf / casement part numbers</b>		Product code:	SS10
Top:	3	<b>Leaf midrail</b>	
Bottom:	2	Manufacturer:	
Lock side:	8	Product name:	
Hinge side:	9	Product code:	
<b>Leaf / casement section size</b>		Material:	
Width:	89 / 136	<b>Leaf / casement joint method</b>	
Depth:	66	Head:	
<b>Reinforcing</b>		Foot:	
Manufacturer:			
Product name:			
Product code:			
Material:			

<b>Leaf, Sash, or Casement - 2</b>			
Width:	1247	<b>Leaf / casement gasket</b>	
Height:	2393	Gasket type:	Silicon
Material:	Pine	Manufacturer:	Sipla AB
Surface finish:	Not painted	Product name:	Gasket 10mm
<b>Leaf / casement part numbers</b>		Product code:	SS10
Top:	4	<b>Leaf midrail</b>	
Bottom:	1	Manufacturer:	
Lock side:	11	Product name:	
Hinge side:	10	Product code:	
<b>Leaf / casement section size</b>		Material:	
Width:	89 / 140	<b>Leaf / casement joint method</b>	
Depth:	66	Head:	
<b>Reinforcing</b>		Foot:	
Manufacturer:			
Product name:			
Product code:			
Material:			

<b>Glazing</b>			
<b>Glass unit</b>		<b>Glazing gasket</b>	
Manufacturer:	PressGlass	Gasket type:	EPDM cellular rubber
Inner thickness:	22mm	Manufacturer:	Trelleborg
Spacer material:	TGI spacer - stainless steel and polypropylene	Product name:	9x4 crown
Outer thickness:	6mm	Product code:	9x4
Unit sizes:	1095x2207	<b>Glazing clip</b>	
<b>Bead</b>		Manufacturer:	Entech
Manufacturer:	HYDRO	Product name:	Glazing clips
Product name:	Glazing beads	Product code:	
Product code:	362915 / 362914	<b>Glazing tape details</b>	
Bead size:	20x18	Manufacturer:	
Bead material:	Aluminium	Product name:	
		Product code:	

Hardware				
	Manufacturer:	Product description:	Product code:	Quantity:
Hinges:				
Hinge fixing:				
Hinge protectors:				
Hinge protector fixings:				
Locking hardware:	SIEGENIA	Locking gear	PKGB0060	1
Locking hardware fixing:	SIEGENIA	Locking bolts	PRTB0010	4
Cylinder:	ISEO	PZ40-60	I-820940609-K010	1
Cylinder fixing:				
Handle:	SIEGENIA	Inside and outside handle set	PMHB0040 / PMHB0050	1
Handle fixings:				
Touch bar:				
Cylinder support:				
Cylinder escutcheon:				
Keeps:				
Keep fixings:				
Drip bar:				
Drip bar fixings:				
Any additional hardware:				

#### Confirmation

Customer is to confirm that the samples provided for testing are representative of standard production. Please note: the details given above, as well as the drawings supplied by the customer as confirmed as typical of normal production are not verified by UL International (UK) Limited.

Company:	Panorma Nordic
Name:	Povilas Jaseliūnas
Position:	Technologist
Date:	2025-08-28



## 4. Test Arrangement

### 4.1 Environmental conditioning

The test samples were stored in a non-destructive laboratory environment within a temperature range of 15 to 30°C, and a humidity range of 25 to 75% RH, for a minimum of 12 hours prior to testing. These conditions were maintained during the test.

### 4.2 Test rig

The test sample was supplied mounted in a 140x75 mm Timber sub-frame in accordance with manufacturer's installation requirements. The sample was installed into the test rig, which was constructed to meet the requirements of the test specification, and was installed plumb, square and without twist or bends.

Figure 1 – Test rig used for testing

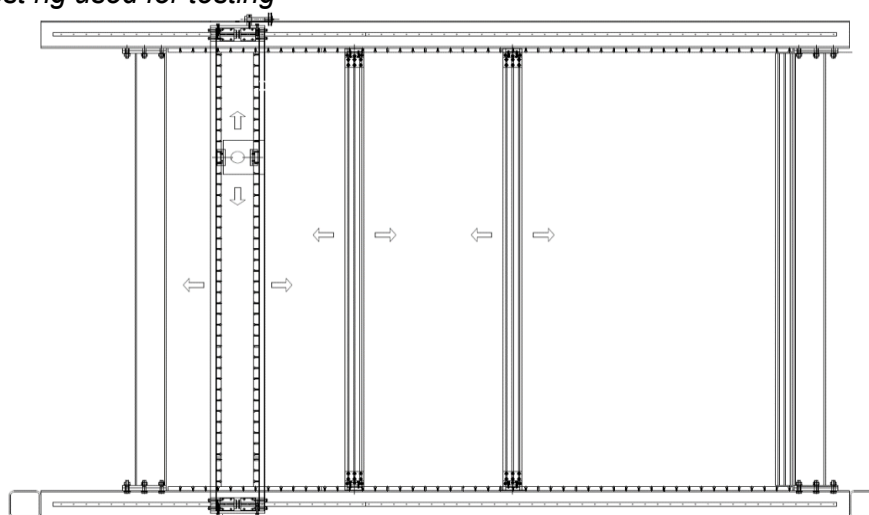

### 4.3 Mechanical load application

A series of parallel to plane loads and perpendicular to plane loads were applied to the products using hydraulic cylinders. The loads parallel and perpendicular to the plane of the test sample were applied to within a measured accuracy of  $\pm 2\%$ . Perpendicular-to-plane loads were controlled to an accuracy of  $\pm 5\%$ , and they were applied within  $5^\circ$  perpendicular to the plane of the sample.

Mechanical loading to the door leaf was applied by a pad with a nominal area of 1,000mm<sup>2</sup> with a minor dimension of not less than 20mm.

Mechanical loading to the infill was applied with a pad (as described above) centrally attached to a 150x150 $\pm 5$  mm plywood pad with a thickness of not less than 25mm.

### 4.4 Attack tool groups

The following list of tools were available for use during the relevant manual attack tests.

The tools were not used to strike the test sample, or strike one another, nor were they connected in any way to increase the leverage available during any of the manual attack tests.

#### 4.4.1 Tool group A

Section reference	Tool description
A.2.2.1	Assorted mild steel wire
A.2.2.2	Two credit cards
A.2.2.3	Two paint scrapers
A.2.2.4	One craft knife
A.2.2.5	Two flat blade screwdrivers, 150mm length

#### 4.4.2 Tool group B

Section reference	Tool description
A.2.3.1	One 25mm wood chisel
A.2.3.2	One 6mm wood chisel
A.2.3.3	One flat blade screwdriver, 200mm length
A.2.3.4	One brick bolster
A.2.3.5	One cross point screwdriver, 200mm length
A.2.3.6	One cross head screwdriver, 200mm length
A.2.3.7	One interchangeable bit screwdriver, 200mm length, PH1 to PH3, PZ1 to PZ3, T5 to T30, H2 to H6, Hexagon heads range from 4mm to 10mm and slotted 3.5mm to 6.5mm bits. This screwdriver was only used for removal of exposed fixings if applicable.

#### 4.4.3 Tool group C

Section reference	Tool description
A.2.4.1	One pair of self-gripping pliers
A.2.4.2	One torque gauge
A.2.4.3	One shallow curve head attachment
A.2.4.4	One hooked head attachment
A.2.4.5	A selection of steel self-cutting traction screws with deep thread and gimlet point, self-tapping thread with drill point, single and twin start.

### 4.5 Soft body impactor

The soft body impact energy was applied by the pendulum fall of a leather sphericoconical bag of approximately 1100 ±80 mm circumference filled with fine dry sand to a total mass of 30 ±0.05 kg (this corresponds to a sand density of 1 500 kg/m<sup>3</sup> and a grain size of <2 mm). The impactor was suspended by a cable of at least 1.5 m in length, such that the movement of the impactor is in a vertical plane perpendicular, ±5°, to the impacted face of the component.

### 4.6 Hard body impactor

The hard body impact energy was applied by the pendulum fall of a cylindrical steel block having a mass of  $50 \pm 0.05$  kg\*. The nose of the impactor was  $50 \pm 0.5$  mm in diameter and  $175 \pm 35$  mm in length. The overall length of the impactor was  $820 \pm 10$  mm. The impactor was arranged to swing in an arc normal to the plane of the door and its longitudinal axis was horizontal at the moment of impact.

*\*Deviation from the standard –The uncertainty of measurement was accounted when checking mass of the hard body impactor used during testing and it has been recorded as  $\pm 0.09$  kg which exceeds the required by the standard tolerance.*

## **4.7 Entry cylindroids**

### **4.7.1 Entry definition cylindroid**

A  $500 \pm 25$  mm long cylindroid of a diameter  $50 \pm 0.5$  mm was used to confirm that any aperture created did not satisfy the entry definition as of section 3.9 in PAS 24:2022, for any relevant tests.

### **4.7.2 Entry definition ellipsoid**

A  $500 \pm 25$  mm long cylindroid with an elliptical section of  $225 \pm 2$  mm minor and  $380 \pm 2$  mm major diameters was used to confirm that any aperture created during the Manual cutting test in zone 2 did not satisfy the entry definition as of section 3.10 in PAS 24:2022.

# 5. Test Procedures

## 5.1 Security hardware & cylinder test

The objective of this test was to assess the lock and cylinder and its resistance to manual attack when using the tools as described in section A.2 of PAS 24:2022.

The test was broken into 3 separate parts which are as follows:

### 5.1.1 Part 1

The hardware was attacked for a total of 3 minutes which consisted of the following activities:

- i. Attempts to remove, dislodge or otherwise gain access to the cylinder and lock by attacking any protective item.
- ii. Attempts to break or defeat the cylinder by applying a twisting or bending force.
- iii. Attempts to operate any accessible mechanism in order to gain entry.

### 5.1.2 Part 2

The hardware was attacked for a total of 3 minutes which consisted of the following activities:

- i. Attempts to remove, dislodge or otherwise gain access to the cylinder and lock by attacking any protective item.
- ii. Attempts to screw self-cutting screws into the exposed part of the cylinder in order to provide a suitable fixing force for activity iii.
- iii. Attempts to break and defeat the cylinder by applying a nominally axial force to the screw using a hooked head crowbar attachment.
- iv. Attempts to operate any accessible mechanism in order to gain entry.

### 5.1.3 Part 3

The hardware was attacked for a total of 3 minutes which consisted of the following activities:

- i. Attempts to remove, dislodge or otherwise gain access to the lock mechanism by attacking any item protecting the lock mechanism.
- ii. Attempts to defeat the lock and expose mechanisms within the lock case.
- iii. If access to the internal workings of the hardware, cylinder or lock is gained, then attempts to defeat the lock and gain entry by operating any accessible mechanism.

## 5.2 Manual check test

The objective of the manual check test is to explore the possibility that there might be weaknesses and vulnerabilities in the product that are not covered in the standard loading cases.

The objective of this test was to assess any vulnerabilities of the sample that are not covered by the standard loading cases assessed in the mechanical loading test B.4.5. The tools described in section B.4.6.2 of PAS 24:2022 were used for a maximum period of 15 minutes in an attempt to gain entry through the sample. No single location was tested for more than 6 minutes with no single attack technique being used for more than 3 minutes.

### **5.3 Infill – mechanical test**

The objective of this test was to assess the ability of any infill medium to withstand a load of 2.0 kN applied to the exterior face at each corner. The load was applied to the top left corner before working clockwise around the remaining corners of the infill medium. The force was applied over a period of between 10 and 20 seconds and the force maintained until it had been held for between 8 to 12 seconds.

The loads and loading sequence were in accordance with section B.4.4.3 of PAS 24:2022.

### **5.4 Manipulation test (a)**

The objective of this test was to highlight any inherent vulnerability in the design of the door which, from the outside, would permit entry by the hardware being operated, released or disengaged when tested using all of tools group A from section A.2.1 of PAS 24:2022 and, where applicable, tools specified in A.2.3.3, A.2.3.5 and A.2.3.6 in tools group B from section A.2.3.7 of PAS 24:2022. The overall attack time was limited to 15 minutes, with unlimited rest time and with no single test technique being used for more than 3 minutes.

### **5.5 Manual cutting test**

The objective of this test was to cut an aperture in the infill or fabric of the door leaf in order to gain entry using the tools described in section A.2.2.3, A.2.2.4, A.2.3.1 and A.2.4.2. Two tests were conducted: An attack in Zone 1 and a second in Zone 2. The overall attack time for each test was 3 minutes.

Zone 1 is a horizontal band with an upper limit 400 mm (+0 mm / -10 mm) above the centre of rotation of the upper hardware unlocking point and a lower limit 400 mm (+0 mm / -10 mm) below the centre of the rotation of the lower unlocking point as shown below. In the case of a single hardware unlocking point zone 1 is a horizontal band with limits 400 mm (+0 mm / -10 mm) above and below the centre of rotation of the hardware unlocking point. Zone 2 covers any point of the doorset not in zone 1.

### **5.6 Mechanical loading test**

The objective of this test was to assess whether the sample is capable of withstanding a specified sequence of mechanical loads without creating an entry.

Parallel-to-plane loads were applied progressively and without shock over a period of 10 and 20 seconds. The parallel-to-plane loads were applied until the perpendicular-to-plane loading, which was held between 8 and 12 seconds, was completed and removed. The loads were removed without shock over a period which did not exceed 20 seconds.

The loads and loading sequence were in accordance with section B.4.5 of PAS 24:2022.

### **5.7 Infill – Manual test**

The objective of this test was to attempt to remove gaskets, beads, security devices (if applicable) and the infill, using tools group A and tools group B described in section A.2.1 & A.2.2 of PAS 24:2022 for a maximum period of 3 minutes.

### **5.8 Soft body impact test**

The objective of this test was to assess the ability of the sample to resist impacts using a soft body impactor as shown in figure B.11 of PAS 24:2022 and at various impact locations specified in section B.4.8.2 of PAS 24:2022.

### **5.9 Hard body impact test**

The objective of this test was to assess the hardware, infill medium and its retention system to hard body impacts using the impactor as shown in figure B.12 of PAS 24:2022. Impacts were conducted at various locations specified in section B.4.9.2 of PAS 24:2022.

### **5.10 Entry definitions**

The performance of the door was measured against the entry definitions as described in 3.10 PAS 24:2022.

For the manual cutting test in zone 2 an attempt was made to pass the 500 mm long cylindroid with an elliptical section of 225 mm minor and 380 mm major diameters through any aperture created.

For all other tests attempts were made to pass the 500 mm long cylindroid of diameter 50 mm through any aperture(s) created.

# 6. Test Results

## 6.1 Laboratory conditions

Prior to the start of the test, the laboratory conditions were measured as follows:

Date(s)	26 <sup>th</sup> August 2025	8 <sup>th</sup> September 2025
Temperature (°C)	19.3	20.9
Humidity (%R- H)	59.3	48.9

**Note:** *The test samples were stored in a non-destructive environment at a temperature of 15 – 30°C for a minimum of 12 hours, testing was also conducted at those conditions.*

## 6.2 Locking condition

Before testing, the door was closed and locked in the most onerous condition based on its intended use and any keys were removed.

Tested locking condition	Active Leaf Locked & Key removed
--------------------------	----------------------------------

## 6.3 Security hardware & cylinder test

Attempts were made from the external face to operate, release and disengage the system hardware to gain entry through the sample in accordance with section A.3 of PAS 24:2022.

No entry was gained during the attack time.

## 6.4 Manual check test

Attempts were made from the external face to gain entry through the sample by applying load combinations not covered by the standard loading cases for the mechanical loading test. The overall attack time was limited to 15 minutes with no single attack technique being used for more than 3 minutes and no single location being attacked for more than 6 minutes.

No entry was gained during this test.

## 6.5 Infill – mechanical test

A series of loads were applied to the external face of the infill as defined in section B.4.4.3 of PAS 24:2022. A perpendicular-to-plane load of 2.0kN was applied and held for 8-12 seconds at each corner of the infill. Starting in the top left corner and working clockwise in turn and in a direction towards the inside.

No entry was gained during this test.

## 6.6 Manipulation test (a)

Attempts were made from the external face to operate, release and disengage the system hardware to gain entry through the sample in accordance with section C.4.3 of PAS 24:2022. The results are as follows:

Location	Tools used	Method	Time	Entry gained
1-locking point	2X Paint scrapers	tried to manipulate hardware	3	No Entry Gained
2-locking point	2X Paint scrapers	tried to manipulate hardware	3	No Entry Gained
3-roller	2X Paint scrapers	tried to manipulate hardware	3	No Entry Gained
4-roller	2X Paint scrapers	tried to manipulate hardware	3	No Entry Gained
5-interlock	2X Paint scrapers	tried to manipulate hardware	3	No Entry Gained

Figure 2 – Attack locations

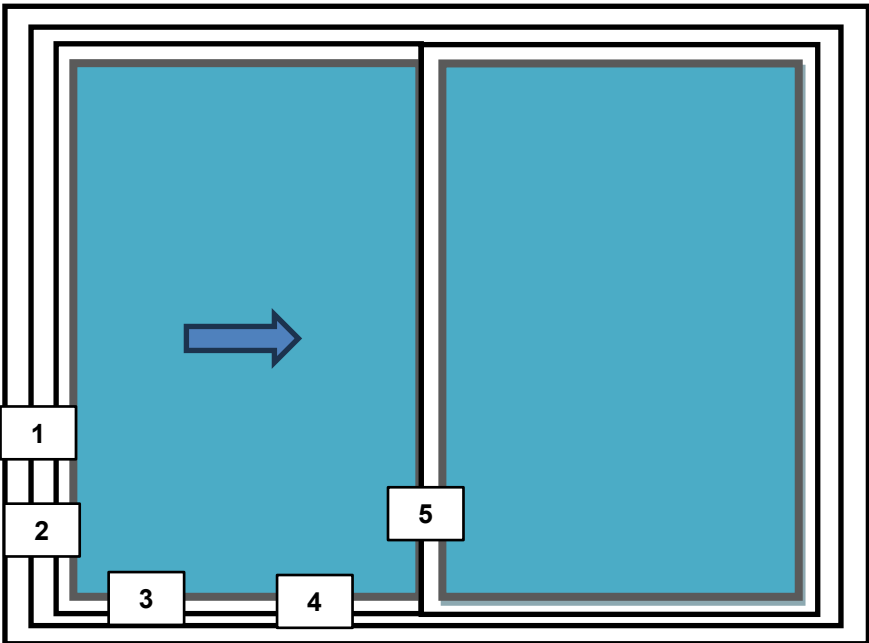

## 6.7 Manual cutting test

Attempts were made from the external face to cut an aperture in the infill or fabric of the door leaf to gain access using tools as described in section A.2.2.3, A.2.2.4, A.2.3.1 and A.2.3.2 of PAS 24:2022. Two tests were carried out; An attack in zone 1 and a second in zone 2 as defined in section B.4.4.4 of PAS 24:2022. The overall attack time for each test was 3 minutes.

No entry was gained during this test.

## 6.8 Mechanical loading test

A series of loads were applied to the door leaf as defined in section B.4.5 of PAS 24:2022. The loading combinations used were as defined in table B.1 to table B.6 of PAS 24:2022 for the applicable door type and were applied as shown in the table below:

Loading point		Parallel-to-plane load			Perpendicular-to-plane load			Result	
		Target (kN)	Applied (kN)	Direction	Target (kN)	Applied (kN)	Direction		
1	Non Meeting corner	4.5	4.464	→	1.5	1.542	-	-	<b>Pass</b>
1	Non Meeting corner	1.5	1.500	↓	4.5	4.416	-	-	<b>Pass</b>
2	Locking point	1.5	1.544	↑	4.5	4.436	-	-	<b>Pass</b>
2	Locking point	1.5	1.530	→	4.5	4.416	-	-	<b>Pass</b>
2	Locking point	4.5	4.444	→			-	-	<b>Pass</b>
3	Locking point	1.5	1.526	↑	4.5	4.414	-	-	<b>Pass</b>
3	Locking point	1.5	1.494	→	4.5	4.434	-	-	<b>Pass</b>
3	Locking point	4.5	4.486	→			-	-	<b>Pass</b>
4	Locking point	1.5	1.536	↑	4.5	4.414	-	-	<b>Pass</b>
4	Locking point	1.5	1.548	→	4.5	4.412	-	-	<b>Pass</b>
4	Locking point	4.5	4.498	→			-	-	<b>Pass</b>
5	Locking point	1.5	1.536	↑	4.5	4.416	-	-	<b>Pass</b>
5	Locking point	1.5	1.508	→	4.5	4.396	-	-	<b>Pass</b>
5	Locking point	4.5	4.478	→			-	-	<b>Pass</b>
6	Non Meeting corner	4.5	4.400	→	1.5	1.528	-	-	<b>Pass</b>
6	Non Meeting corner	1.5	1.574	↑	4.5	4.408	-	-	<b>Pass</b>
7	Roller	4.5	4.484	↑	1.5	1.534	-	-	<b>Pass</b>
8	Roller	4.5	4.596	↑	1.5	1.584	-	-	<b>Pass</b>
9	Meeting corner/interlock	-	-	↓	4.5	4.412	4.404	-	<b>Pass</b>
9	Meeting corner/interlock	1.5	1.500	↑	4.5	4.386	-	-	<b>Pass</b>
10	Corner of fixed	1.5	1.540	↑	4.5	4.426	-	-	<b>Pass</b>
10	Corner of fixed	1.5	1.544	→	4.5	4.418	-	-	<b>Pass</b>
11	Interlock	-	-	↓	4.5	4.470	4.398	-	<b>Pass</b>
12	Interlock	-	-	↓	4.5	4.442	4.388	-	<b>Pass</b>
13	Centre of fixed	1.5	1.506	→	4.5	4.406		-	<b>Pass</b>

14	Interlock	-	-	↕	4.5	4.544	4.492	-	<b>Pass</b>
15	Meeting corner/interlock	-	-	↕	4.5	4.446	4.412	-	<b>Pass</b>
15	Meeting corner/interlock	1.5	1.536	↓	4.5	4.434	-	-	<b>Pass</b>
16	Corner of fixed	1.5	1.522	↓	4.5	4.422	-	-	<b>Pass</b>
16	Corner of fixed	1.5	1.556	→	4.5	4.424	-	-	<b>Pass</b>
17	Centre of fixed	1.5	1.566	↓	4.5	4.422	-	-	<b>Pass</b>
18	Corner of fixed	1.5	1.530	↓	4.5	4.440	-	-	<b>Pass</b>
18	Corner of fixed	1.5	1.622	←	4.5	4.428	-	-	<b>Pass</b>
19	Centre of fixed	1.5	1.722	←	4.5	4.562	-	-	<b>Pass</b>
20	Corner of fixed	1.5	1.574	↑	4.5	4.526	-	-	<b>Pass</b>
20	Corner of fixed	1.5	1.534	←	4.5	4.424	-	-	<b>Pass</b>
21	Centre of fixed	1.5	1.572	↑	4.5	4.436	-	-	<b>Pass</b>

Figure 3 – Loading points

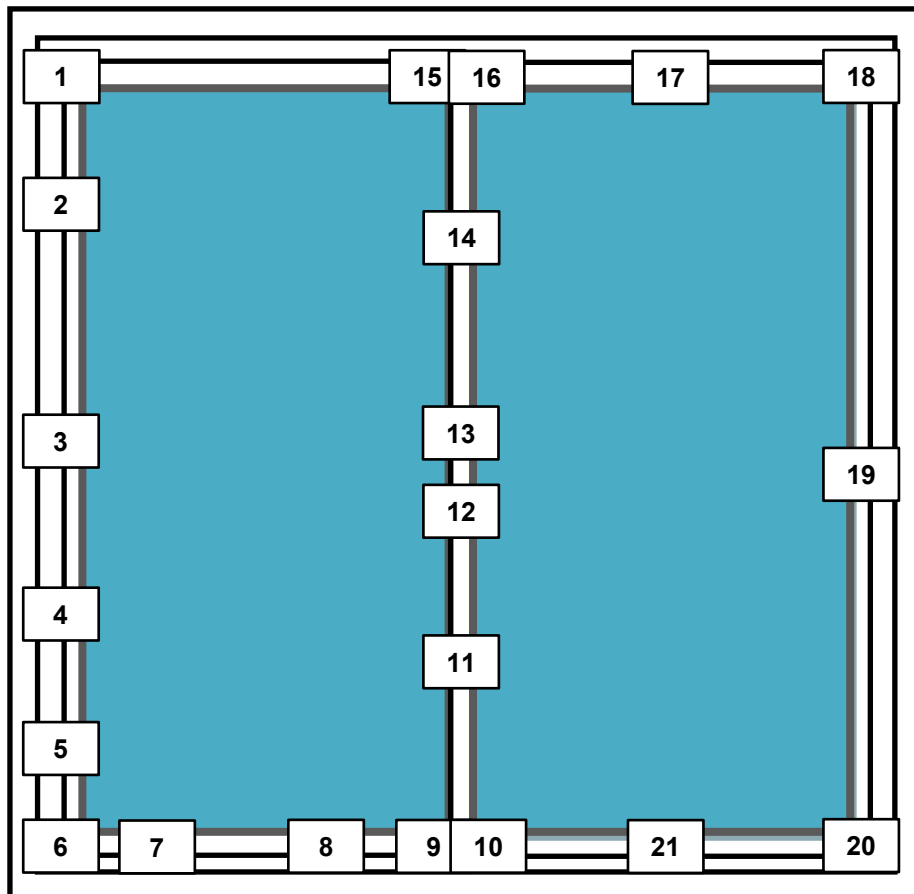

**6.11 Infill manual test**

Attempts were made from the external face to remove gaskets and beading to gain access to and remove the infill using tools A.2.1 & A.2.2 in accordance with section B.4.4.2 of PAS 24:2022.

No entry was gained during this test.

**6.12 Soft body impact test**

The test sample was subject to soft body impacts on the external face as shown in figure 4. Each of the locations was subject to 3 impacts from a drop height of 800mm.

No damage was observed nor was entry gained during the test.

Figure 6 – Impact locations

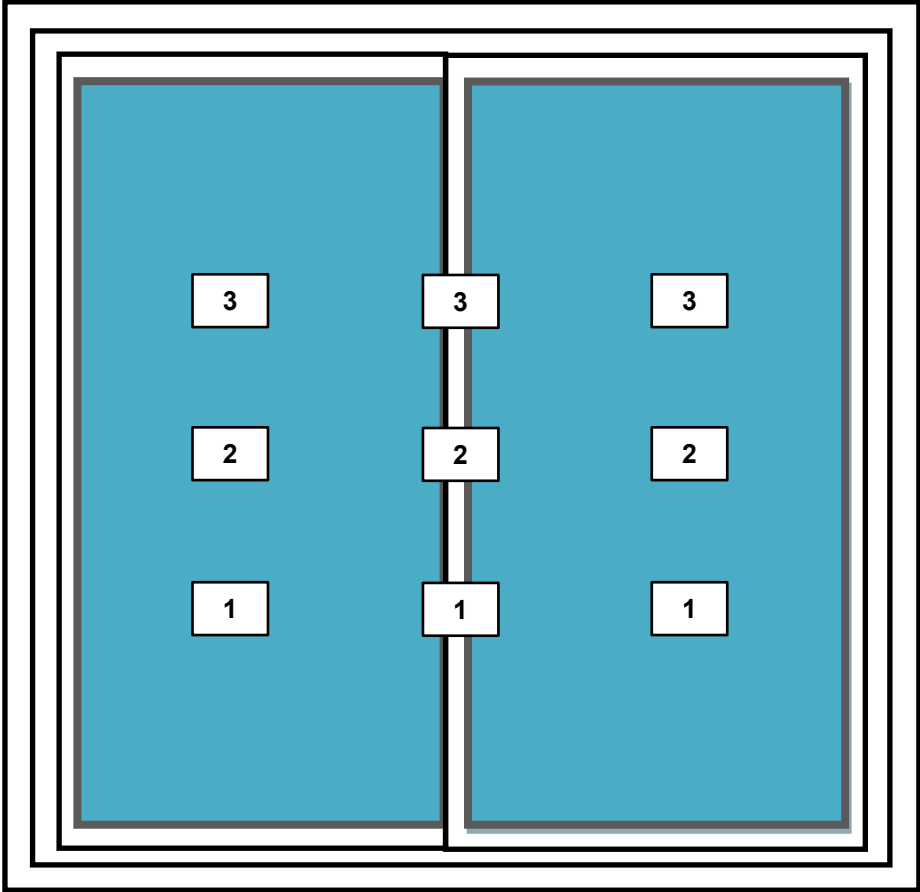

**6.13 Hard body impact test**

The test sample was subject to hard body impacts on the external face in accordance with section B.4.9.2 of PAS 24 2022. Each of the impact locations was subject to 3 impacts from a drop height of 165 mm and the result compared with the relevant entry definition.

No damage was observed nor was entry gained during the test.

# 7. System Drawings

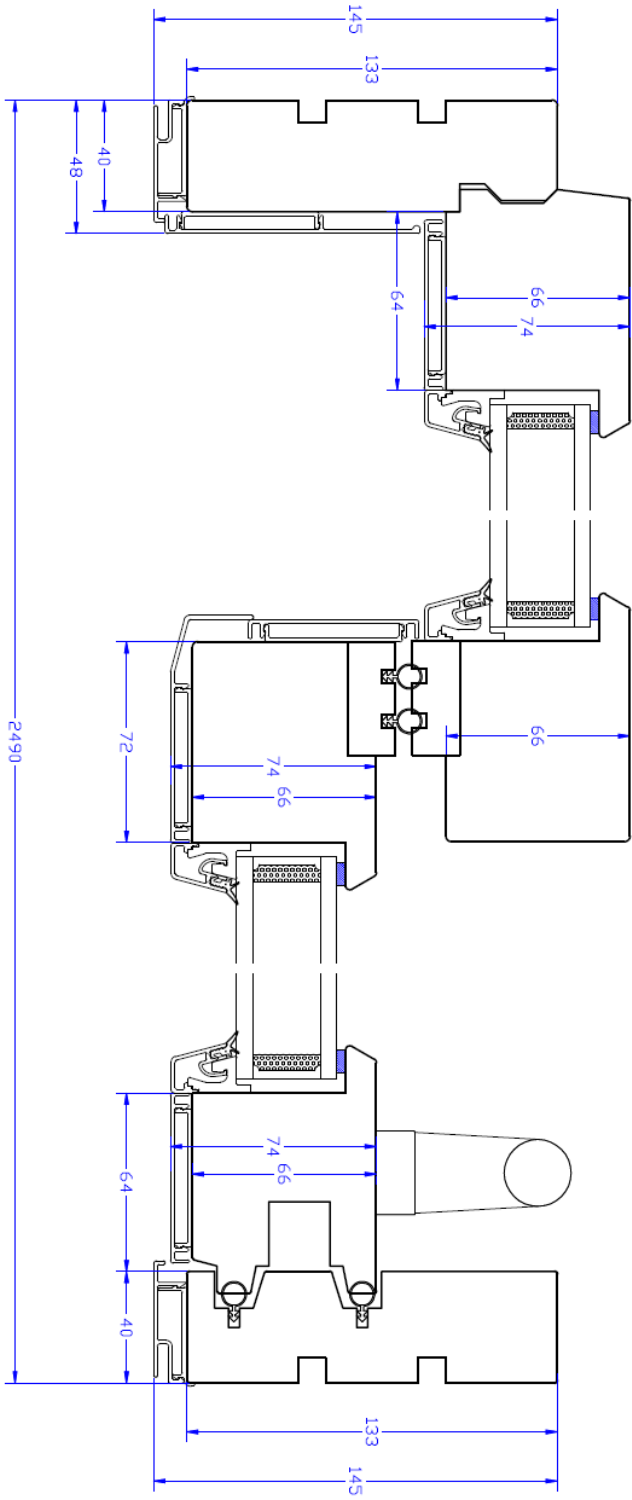

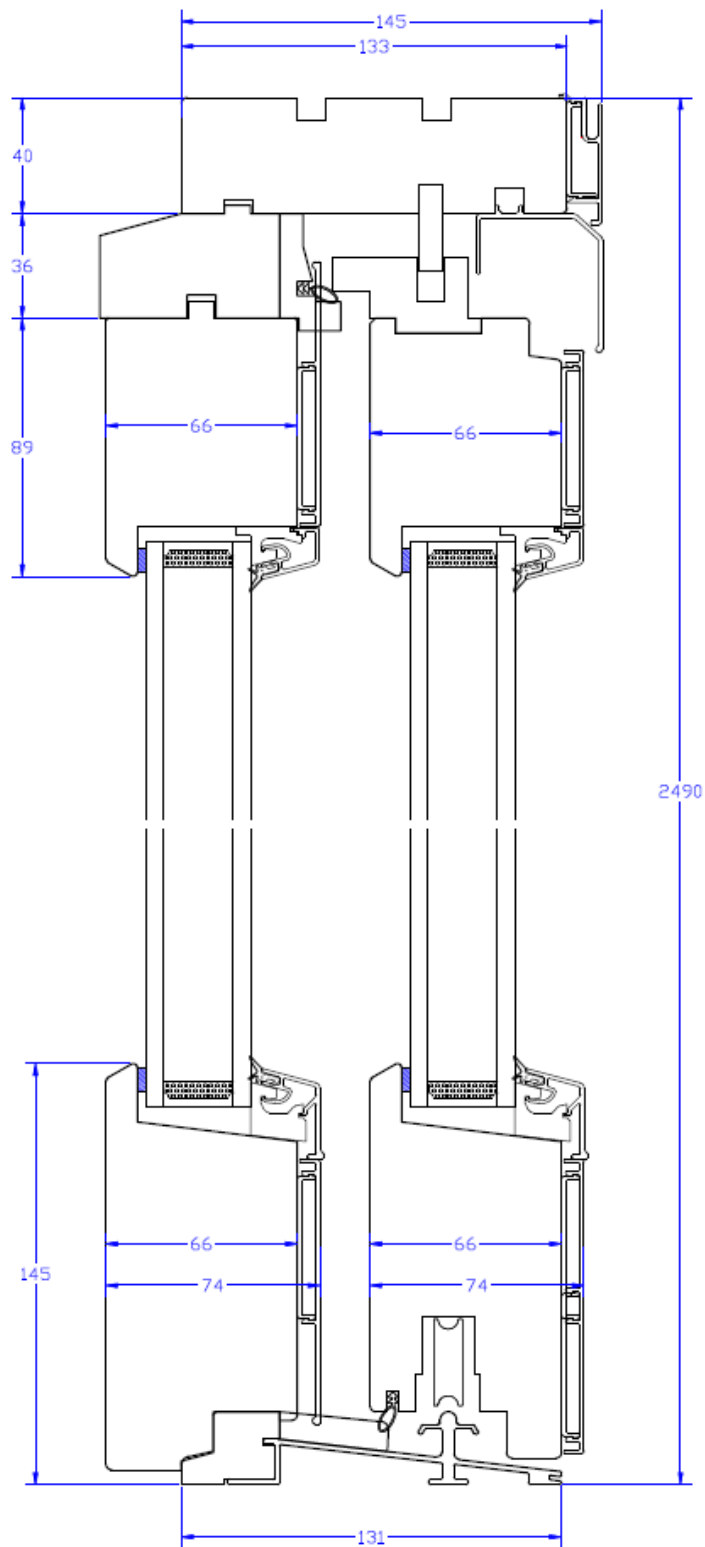

----- END OF REPORT -----